



US006654443B1

(12) **United States Patent**  
**Hoffman**

(10) **Patent No.:** **US 6,654,443 B1**  
(45) **Date of Patent:** **Nov. 25, 2003**

(54) **THERMAL SENSING DETECTOR CELL FOR A COMPUTED TOMOGRAPHY SYSTEM AND METHOD OF MANUFACTURING SAME**

2002/0131626 A1 \* 9/2002 Vogtmeier et al. .... 382/131

\* cited by examiner

(75) Inventor: **David M. Hoffman**, New Berlin, WI (US)

*Primary Examiner*—Eric S. McCall

(73) Assignee: **GE Medical Systems Global Technology Co., LLC**, Waukesha, WI (US)

(74) *Attorney, Agent, or Firm*—Ziolkowski Patent Solutions Group, LLC; Michael A. Della Penna; Carl B. Hornton

(\* ) Notice: Subject to any disclaimer, the term of this patent is extended or adjusted under 35 U.S.C. 154(b) by 18 days.

(57) **ABSTRACT**

The present invention provides a detector cell having an x-ray absorption component and a thermal sensing component configured to detect thermal differentials in the absorption component resulting from the absorption of x-rays. The absorption component comprises high density materials that respond thermally to the reception of x-rays or other HF electromagnetic energy. The thermal sensing component detects the changes in temperature of the absorption component and outputs electrical signals indicative of the number and intensity of the x-rays absorbed. An image reconstructor then processes those electrical signals to reconstruct an image of the subject scanned. A method of manufacturing the detector cell is also provided.

(21) Appl. No.: **09/683,869**

(22) Filed: **Feb. 25, 2002**

(51) **Int. Cl.**<sup>7</sup> ..... **G06K 9/00**

(52) **U.S. Cl.** ..... **378/19; 250/370.01; 250/370.08; 250/370.09**

(58) **Field of Search** ..... **378/19; 250/370.01, 250/370.08, 370.09**

(56) **References Cited**

**U.S. PATENT DOCUMENTS**

6,263,046 B1 \* 7/2001 Rogers ..... 378/141

**19 Claims, 4 Drawing Sheets**

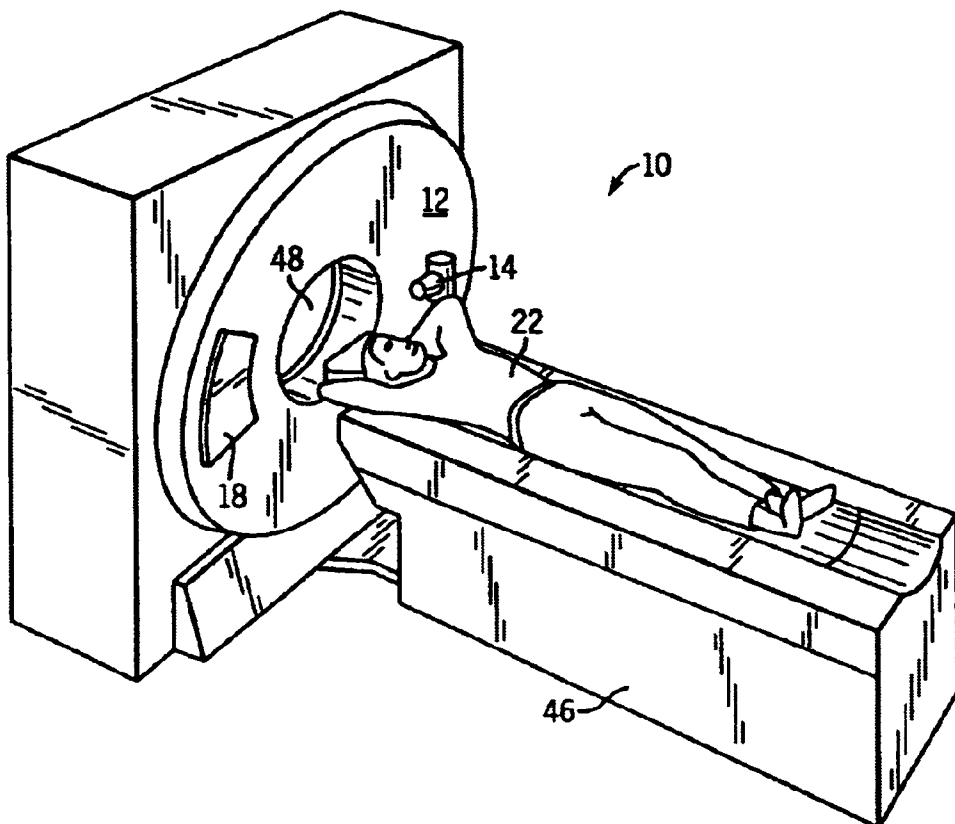

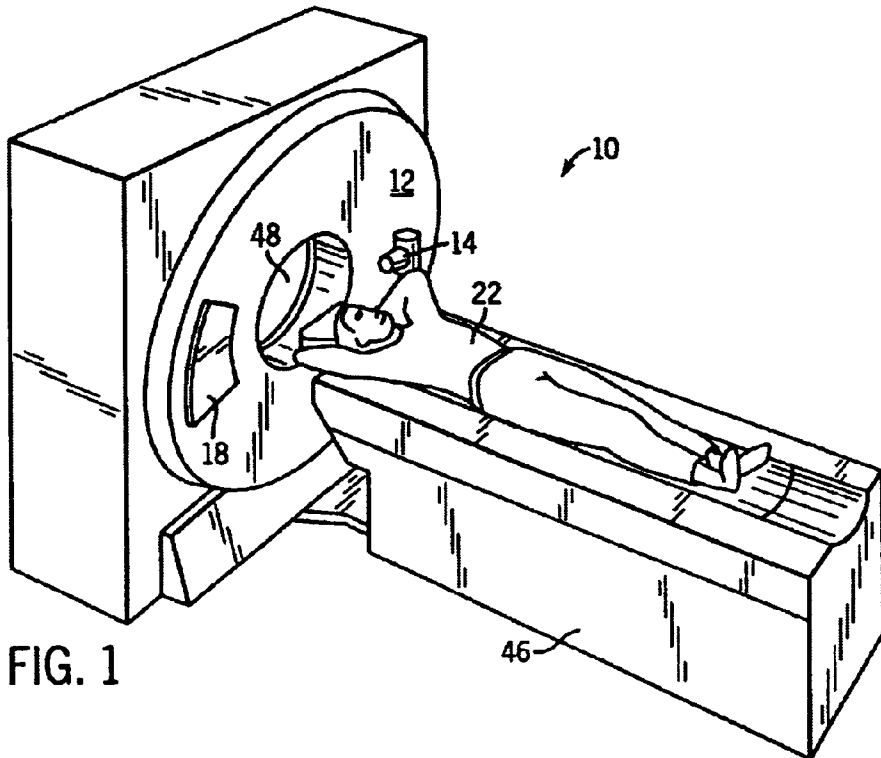

FIG. 1

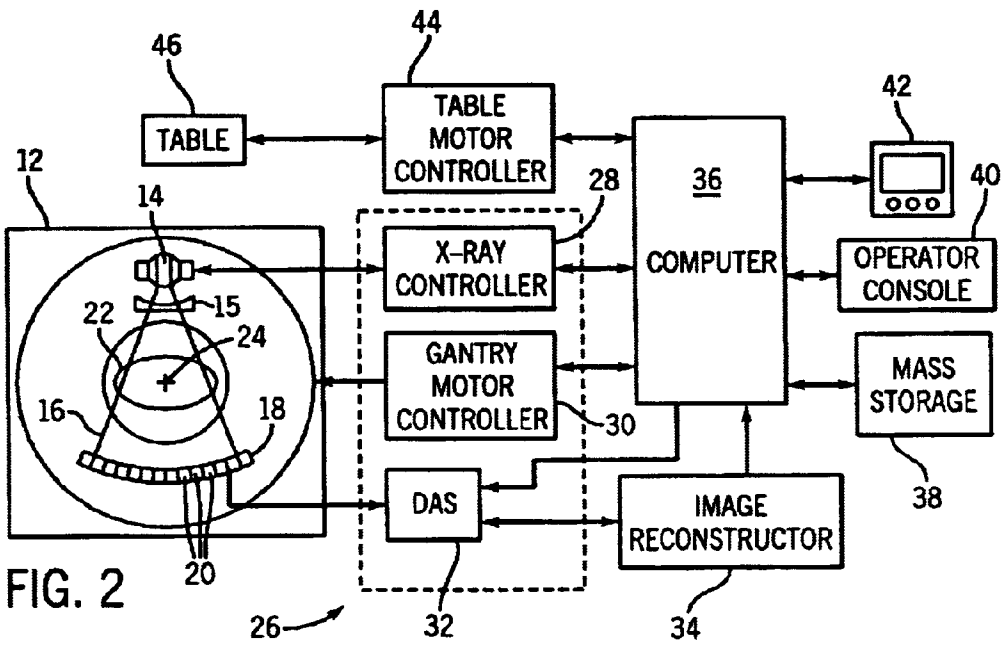

FIG. 2

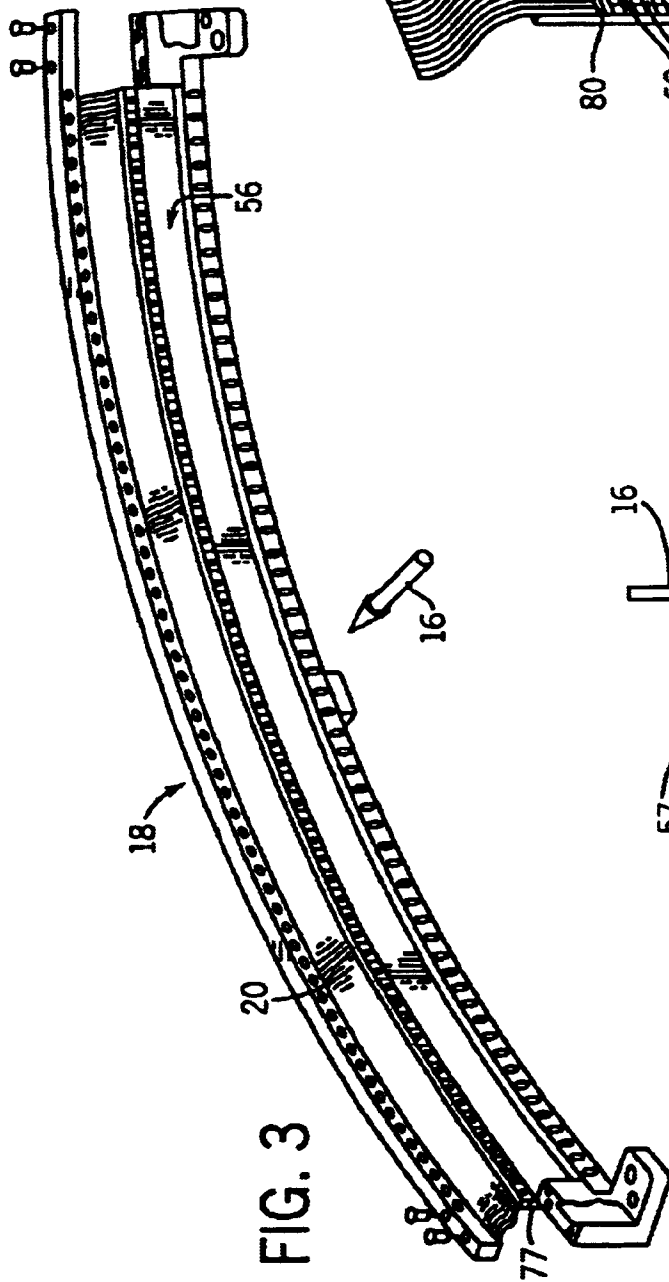

FIG. 3

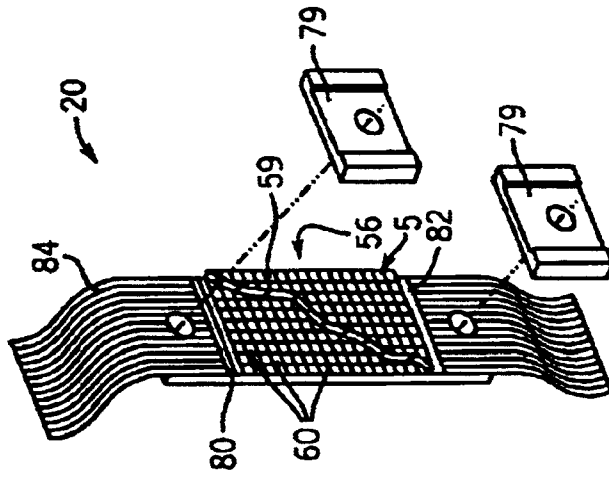

FIG. 4

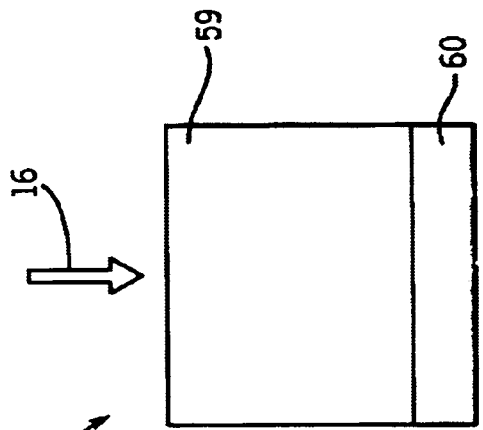

FIG. 6

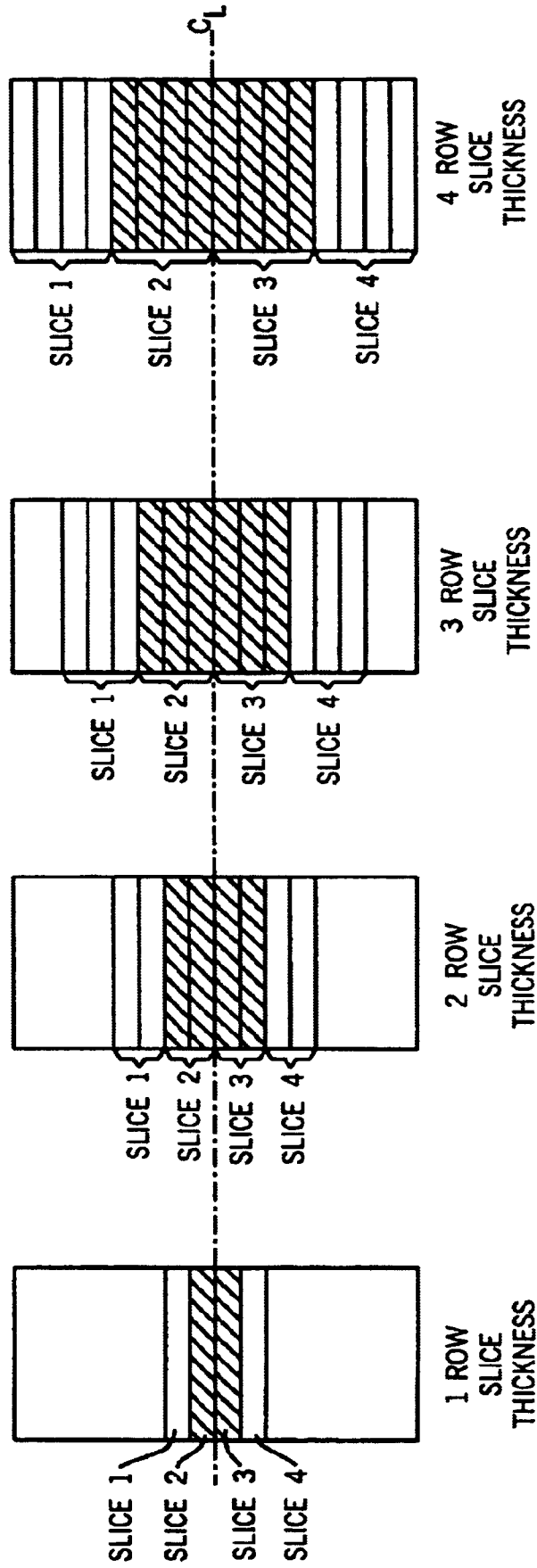
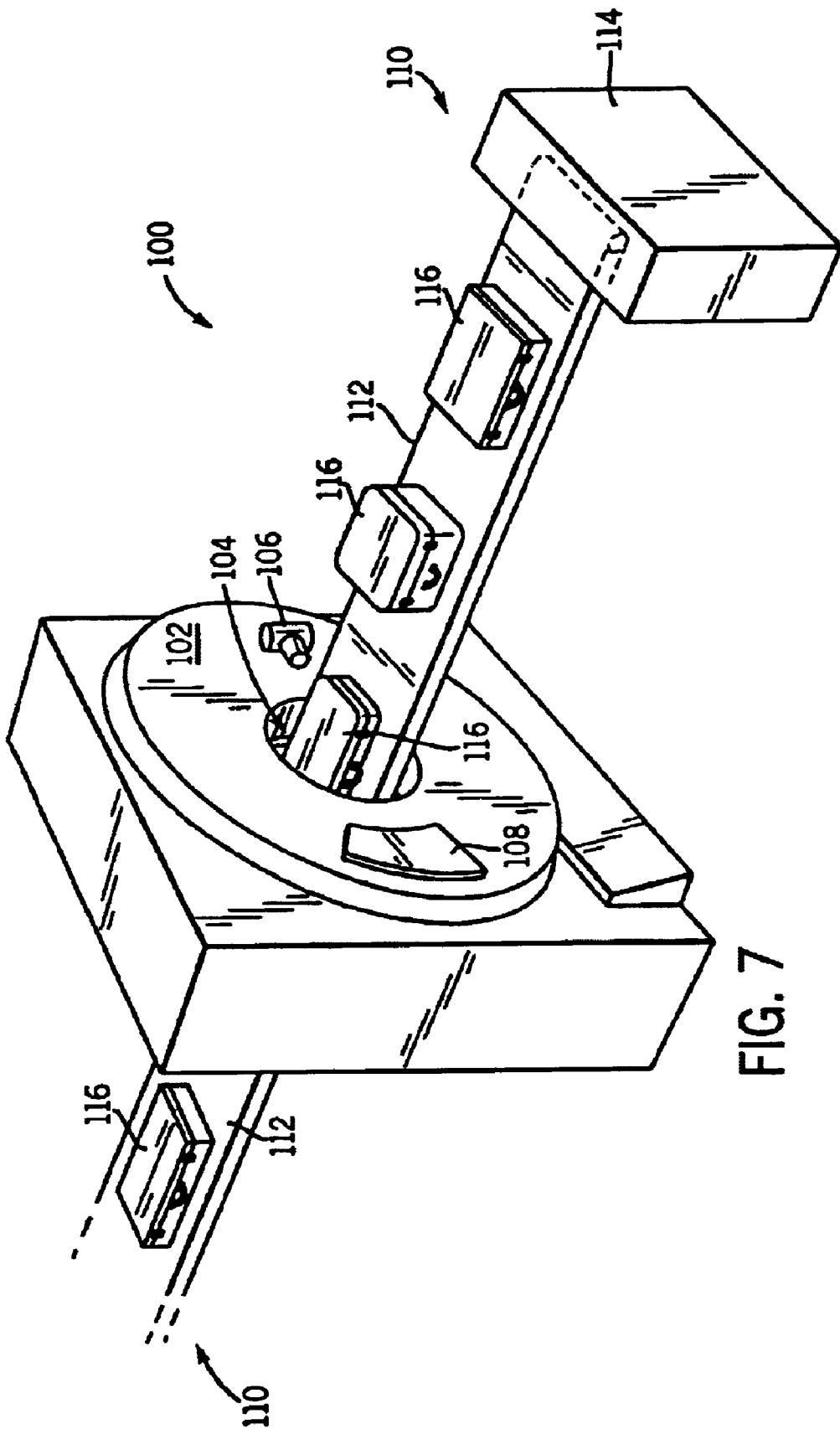

FIG. 5



**THERMAL SENSING DETECTOR CELL FOR  
A COMPUTED TOMOGRAPHY SYSTEM  
AND METHOD OF MANUFACTURING  
SAME**

**BACKGROUND OF THE INVENTION**

The present invention relates generally to computed tomography imaging and, more particularly, to a detector cell for sensing thermal changes in response to the absorption of HF electromagnetic energy for use with computed tomography systems.

Typically, in computed tomography (CT) imaging systems, an x-ray source emits a fan-shaped beam towards a subject or object, such as a patient or a piece of luggage. Hereinafter the terms "subject" and "object" shall include anything capable of being imaged. The beam, after being attenuated by the subject, impinges upon an array of radiation detectors. The intensity of the attenuated beam radiation received at the detector array is typically dependent upon the attenuation of the x-ray beam by the subject. Each detector element of the detector array produces a separate electrical signal indicative of the attenuated beam received by each detector element. The electrical signals are transmitted to a data processing system for analysis which ultimately results in the formation of an image.

Generally, the x-ray source and the detector array are rotated about the gantry within an imaging plane and around the subject. X-ray sources typically include x-ray tubes, which emit the x-ray beam at a focal point. X-ray detectors typically include a collimator for collimating x-ray beams received at the detector, a scintillator for converting x-rays to light energy adjacent the collimator, and photodiodes for receiving the light energy from the adjacent scintillator. Each scintillator of a scintillator array converts x-rays to light energy. Each scintillator discharges light energy to a photodiode adjacent thereto. Each photodiode detects the light energy and generates a corresponding electrical signal. The outputs of the photodiodes are then transmitted to a data processing system.

With these known scintillators, the scintillating component must be of sufficient thickness to generate the requisite efficient x-ray detection. As a result, a minimum scintillating material thickness is necessary for proper signal to noise generation by the photodiode. The minimum requirements yield higher costs as well as limit the ability to reduce the overall detector cell size and spatial resolution of the detector. Furthermore, detection inefficiencies in this two step detection process, x-rays to light and light to electrical signals, has efficiency losses resulting in a diagnostic image of poorer quality or lower sensitivity.

High density materials may be advantageously used in a detection cell as these materials may absorb HF electromagnetic energy in relatively thin cross-sections. As a result, smaller detector cells can be fabricated increasing system resolution. Moreover, use of materials that change in temperature upon the absorption of HF electromagnetic energy allows for use of thermal sensing components rather than photodiodes thereby producing output signals more indicative of the HF electromagnetic energy detected resulting in a more sensitive and a diagnostic image of greater sensitivity.

It would therefore be desirable to design a detector cell for sensing thermal differentials in the detector cell resulting from the absorption of HF electromagnetic energy thereby providing improved, higher resolution, and more sensitive detector signal output to a data processing system of a CT system.

**BRIEF DESCRIPTION OF INVENTION**

The present invention is directed to a detector cell overcoming the aforementioned drawbacks that generates electrical signals indicative of HF electromagnetic energy absorbed by the detector as defined by thermal differentials within the detector.

In accordance with one aspect of the present invention a CT detector cell is provided and includes an HF electromagnetic energy absorption component comprised of a material configured to change in temperature in response to absorption of HF electromagnetic energy. The CT detector cell further includes a thermal sensing component configured to detect a change in the temperature of the absorption component and output a signal indicative of the HF electromagnetic energy absorbed by the HF electromagnetic energy absorption component.

In accordance with yet another aspect of the present invention, a CT system includes a rotatable gantry having an opening therein and configured to receive a subject to be scanned. The system also includes a subject positioner configured to place the subject to be scanned within the opening and an HF electromagnetic energy projection source configured to project HF electromagnetic energy toward the subject to be scanned. The system also includes an HF electromagnetic energy detector array having a plurality of detector cells which is configured to absorb HF electromagnetic energy passing through the subject to be scanned. Each detector cell includes a HF electromagnetic energy absorption component and a thermal sensing component. The CT system further includes a data acquisition system (DAS) connected to the detector array and configured to receive electrical signals from each thermal sensing component indicative of a change in temperature of a corresponding HF electromagnetic energy absorption component. An image reconstructor is also provided and connected to the DAS and configured to reconstruct an image of the subject from the electrical signals received by the DAS.

In accordance with a further aspect of the present invention, a method of manufacturing a radiation detector sensor array for use with CT systems includes the step of determining a high density material capable of changing in temperature upon absorption of radiation. The method further includes forming an absorption array having a plurality of absorption cells from the high density material. The method also includes coupling a thermal sensing array having a plurality of thermal sensing cells to the absorption array such that each thermal sensing cell corresponds to an absorption cell.

In accordance with yet another aspect of the present invention, a detector array for a CT system includes means for absorbing HF electromagnetic energy and means for experiencing thermal differentials in response to absorbed HF electromagnetic energy. The detector array also includes means for detecting the thermal differentials as well as means for outputting a signal indicative of the HF electromagnetic energy absorbed as defined by detected thermal differentials.

Various other features, subjects and advantages of the present invention will be made apparent from the following detailed description and the drawings.

## BRIEF DESCRIPTION OF DRAWINGS

The drawings illustrate one preferred embodiment presently contemplated for carrying out the invention.

In the drawings:

FIG. 1 is a pictorial view of a CT imaging system.

FIG. 2 is a block schematic diagram of the system illustrated in FIG. 1.

FIG. 3 is a perspective view of one embodiment of a CT system detector array.

FIG. 4 is a perspective view of one embodiment of a detector.

FIG. 5 is illustrative of various configurations of the detector in FIG. 4 in a four-slice mode.

FIG. 6 is a cross-sectional view of one embodiment of the present invention.

FIG. 7 is a pictorial view of a CT system for use with a non-invasive package/luggage inspection system.

## DETAILED DESCRIPTION

The operating environment of the present invention is described with respect to a four-slice computed tomography (CT) system. However, it will be appreciated by those skilled in the art of CT that the present invention is equally applicable for use with single-slice or other multi-slice configurations. Moreover, the present invention will be described with respect to the detection and conversion of x-rays. However, one skilled in the art will further appreciate that the present invention is equally applicable for the detection and conversion of other HF electromagnetic energy. Further, the present invention will be described with respect to a "third generation" CT system. However, the present invention is also applicable with first, second, and fourth generation CT systems.

Referring to FIGS. 1 and 2, a computed tomography (CT) imaging system 10 is shown as including a gantry 12 representative of a "third generation" CT scanner. Gantry 12 has an x-ray source 14 that projects a beam of radiation or x-rays 16 toward a detector array 18 on the opposite side of the gantry 12. Detector array 18 is formed by a plurality of detectors 20 which together sense the projected x-rays that pass through a medical patient 22. Each detector 20 produces an electrical signal that represents the intensity of an impinging x-ray beam and hence the attenuated beam as it passes through the patient 22. During a scan to acquire x-ray projection data, gantry 12 and the components mounted thereon rotate about a center of rotation 24.

Rotation of gantry 12 and the operation of x-ray source 14 are governed by a control mechanism 26 of CT system 10. Control mechanism 26 includes an x-ray controller 28 that provides power and timing signals to an x-ray source 14 and a gantry motor controller 30 that controls the rotational speed and position of gantry 12. A data acquisition system (DAS) 32 in control mechanism 26 samples analog data from detectors 20 and converts the data to digital signals for subsequent processing. An image reconstructor 34 receives sampled and digitized x-ray data from DAS 32 and performs high speed image reconstruction. The reconstructed image is applied as an input to a computer 36 which stores the image in a mass storage device 38.

Computer 36 also receives commands and scanning parameters from an operator via console 40 that has a keyboard or a like data entry module. An associated cathode ray tube display 42 allows the operator to observe the reconstructed image and other data from computer 36. The

operator supplied commands and parameters are used by computer 36 to provide control signals and information to DAS 32, x-ray controller 28 and gantry motor controller 30. In addition, computer 36 operates a table motor controller 44 which controls a motorized table 46 to position patient 22 and gantry 12. Particularly, table 46 moves portions of patient 22 through a gantry opening 48.

As shown in FIGS. 3 and 4, detector array 18 includes a plurality of detectors 20. A collimator 15, as shown in FIG. 2, is positioned to collimate x-ray beams 16 before such beams impinge upon detector array 18.

In one embodiment, shown in FIG. 3, detector array 18 includes 57 pixilated detectors 20, each detector 20 having a plurality of detector cells 57 arranged in an array 56 with a size of 16x16. As a result, array 18 has 16 rows and 912 columns (16x57 detectors) which allows 16 simultaneous slices of data to be collected with each rotation of gantry 12. As will be described with particular reference to FIG. 6, each detector cell 57 includes an x-ray absorption component 59 and a thermal sensing component 60 that, in a preferred embodiment, is affixed to an undersurface of absorption component 59. Array 56 may have a pixilated orientation or, alternatively, a columnar orientation.

Switch arrays 80 and 82, FIG. 4, include multi-dimensional semiconductor arrays coupled between detector array 18 and DAS 32. Switch arrays 80 and 82 further include a plurality of field effect transistors (FET) (not shown) arranged as a multi-dimensional array. The FET array includes a number of electrical leads connected to each of the respective detector cells 57 and a number of output leads electrically connected to DAS 32 via a flexible electrical interface 84. Particularly, about one-half of detector cell outputs are electrically connected to switch 80 with the other one-half of detector cell outputs electrically connected to switch 82. Each detector 20 is secured to a detector frame 77, FIG. 3, by mounting brackets 79.

Switch arrays 80 and 82 further include a decoder (not shown) that enables, disables, or combines detector cell 57 outputs in accordance with a desired number of slices and slice resolutions for each slice. Decoder, in one embodiment, is a decoder chip or an FET controller as known in the art. Decoder includes a plurality of output and control lines coupled to switch arrays 80 and 82 and DAS 32. In one embodiment defined as a 16 slice mode, decoder enables switch arrays 80 and 82 so that all rows of the detector array 18 are activated, resulting in 16 simultaneous slices of data for processing by DAS 32. Of course, many other slice combinations are possible. For example, decoder may also select from other slice modes, including one, two, and four-slice modes.

As shown in FIG. 5, by transmitting the appropriate decoder instructions, switch arrays 80 and 82 can be configured in the four-slice mode so that the data is collected from four slices of one or more rows of detector array 18. Depending upon the specific configuration of switch arrays 80 and 82, various combinations of detector cells 20 can be enabled, disabled, or combined so that the slice thickness may consist of one, two, three, or four rows of detector cells 20. Additional examples include, a single slice mode including one slice with slices ranging from 1.25 mm thick to 20 mm thick, and a two-slice mode including two slices with slices ranging from 1.25 mm thick to 10 mm thick. Additional modes beyond those described are contemplated.

Referring now to FIG. 6, a cross-sectional view of a single detector cell 57 is shown. As indicated previously, each detector cell 57 includes an x-ray absorption component 59

as well as a thermal sensing component **60**. Absorption component **59** is positioned to detect x-rays **16** or other HF electromagnetic energy waves passing through the subject to be scanned, such as, a medical patient as illustrated in FIG. **1**. Preferably, absorption component **59** comprises a high density material that may absorb x-rays in a relatively thin cross-section. Such high density materials may include tungsten, lead, tantalum, or the like. Further, the high density materials should also have a "high z" characteristic or high atomic number. Furthermore, as will be discussed below, the materials used for the absorption component should also have low heat or thermal capacity resulting in significant temperature change in response to x-ray absorption.

The high density, high z materials used to form the absorption component **59** undergo detectable temperature change upon the absorption of x-rays or other HF electromagnetic energy. Several methods may be used to construct an array of absorption components including fabricating a sheet of the selected material and then etching or laser cutting the sheet into pixilated structures. Alternatively, absorption component **59** may also be formed by depositing the absorption materials in collimator structures, or in pixilated structures, or may also be sputtered or vapor deposited and then etched or laser cut. Masking operations may also be utilized to form an array of absorption components.

Still referring to FIG. **6**, coupled to absorption component **59** is a thermal sensing component **60**. Thermal sensing component **60** is configured to detect thermal differentials of absorption component **59** resulting from the absorption of x-rays **16**. The temperature change of the materials detected is proportional to the number and energy of the x-rays absorbed by component **59**. Component **60** detects the thermal change and outputs an electrical signal indicative of the absorbed x-rays. The present invention contemplates several thermal sensing component embodiments including a night vision infrared thermal sensor, a room temperature microbolometer, and other sensitive thermal measuring instrumentation. It should be noted that the temperature change per CT view is an incremental temperature change with each view or increment in time. Therefore, the temperature difference of the detector from view to view must be calculated as a measure of the x-ray intensity absorbed during that particular view.

The present invention may be incorporated into a CT medical imaging device similar to that shown in FIG. **1**. Alternatively, however, the present invention may also be incorporated into a non-invasive package or baggage inspection system, such as those used by postal inspection and airport security systems.

Referring now to FIG. **7**, package/baggage inspection system **100** includes a rotatable gantry **102** having an opening **104** therein through which packages or pieces of baggage may pass. The rotatable gantry **102** houses a HF electromagnetic energy source **106** as well as a detector assembly **108** having detector arrays comprised of detectors similar to that shown in FIGS. **4** and **6**. A conveyor system **110** is also provided and includes a conveyor belt **112** supported by structure **114** to automatically and continuously pass packages or baggage pieces **116** through opening **104** to be scanned. Subjects **116** are fed through opening **104** by conveyor belt **112**, imaging data is then acquired, and the conveyor belt **112** removes the packages **116** from opening **104** in a controlled and continuous manner. As a result, postal inspectors, baggage handlers, and other security personnel may non-invasively inspect the contents of packages **116** for explosives, knives, guns, contraband, etc.

As indicated previously, the present invention contemplates several methods to fabricate a detector cell as

described above. In one preferred embodiment, a thin sheet of absorption component materials is fabricated and immersed in a chemical etchant. After the sheet undergoes immersion for a specific time, the sheet is transferred to a rinse station that assists in removing acid located on the sheet surface. Once the acid is removed, the sheet is rinsed and dried. The chemical etchant facilitates anisotropic etching of unprotected portions of the sheet which aids in the formation of absorption component.

In another preferred embodiment, plasma is applied to the sheet to facilitate the forming of absorption component. To form component, the sheet is loaded into a chamber wherein pressure is reduced by a vacuum system. After the vacuum is established, the chamber is filled with a reactive gas and a frequency field is created through electrodes in the chamber with the aid of a power supply. The frequency field energizes the gas mixture to a plasma state. In the energized state, the gas mixture attacks unprotected portions of the sheet, and converts the sheet into volatile components which are subsequently removed by the vacuum system. When the volatile components are removed, an array of absorption components is formed within the sheet.

In a further embodiment, an array of absorption components may be fabricated using ion beam milling techniques.

Therefore, in accordance with one embodiment of the present invention a CT detector cell is provided and includes a HF electromagnetic energy absorption component comprised of a material configured to change in temperature in response to absorption of HF electromagnetic energy. The CT detector cell further includes a thermal sensing component configured to detect a change in the temperature of the absorption component and output a signal indicative of the HF electromagnetic energy absorbed by the HF electromagnetic energy absorption component.

In accordance with yet another embodiment of the present invention, a CT system includes a rotatable gantry having an opening therein and configured to receive a subject to be scanned. The system also includes a subject positioner configured to place the subject to be scanned within the opening and a HF electromagnetic energy projection source configured to project HF electromagnetic energy toward the subject to be scanned. The system also includes a HF electromagnetic energy detector array having a plurality of detector cells which is configured to absorb HF electromagnetic energy passing through the subject to be scanned. Each detector cell includes a HF electromagnetic energy absorption component and a thermal sensing component. The CT system further includes a DAS connected to the detector array and configured to receive electrical signals from each thermal sensing component indicative of a change in temperature of a corresponding HF electromagnetic energy absorption component. An image reconstructor is also provided and connected to the DAS and configured to reconstruct an image of the subject from the electrical signals received by the DAS.

In accordance with a further embodiment of the present invention, a method of manufacturing a radiation detector sensor array for use with CT systems includes the step of determining a high density material capable of changing in temperature upon absorption of radiation. The method further includes forming an absorption array having a plurality of absorption cells from the high density material. The method also includes coupling a thermal sensing array having a plurality of thermal sensing cells to the absorption array such that each thermal sensing cell corresponds to an absorption cell.



In accordance with yet another embodiment of the present invention, a detector ray for a CT system includes means for absorbing HF electromagnetic energy and means for experiencing thermal differentials in response to absorbed HF electromagnetic energy. The detector array also includes means for detecting the thermal differentials as well as means for outputting a signal indicative of the HF electromagnetic energy absorbed based on the detected thermal differentials.

The present invention has been described in terms of the preferred embodiment, and it is recognized that equivalents, alternatives, and modifications, aside from those expressly stated, are possible and within the scope of the appending claims.

What is claimed is:

1. A CT detector cell comprising:
  - a high frequency (HF) electromagnetic energy absorption component comprised of a material configured to change in temperature in response to absorption of HF electromagnetic energy; and
  - a thermal sensing component configured to detect changes in temperature of the absorption component and output a signal indicative of the HF electromagnetic energy absorbed by the HF electromagnetic energy absorption component based on the detected changes in temperature.
2. The CT detector cell of claim 1 wherein the material includes at least one of tungsten, lead, and tantalum.
3. The CT detector cell of claim 1 wherein the thermal sensing component is affixedly connected to the HF electromagnetic energy absorption component.
4. The CT detector cell of claim 1 wherein the thermal sensing component includes one of an IR thermal sensor and a microbolometer.
5. The CT detector cell of claim 4 wherein the microbolometer includes a room temperature microbolometer.
6. The CT detector cell of claim 1 incorporated as an array in at least one of a medical imaging device and a non-invasive package/baggage inspection device.
7. A CT system comprising:
  - a rotatable gantry having an opening therein and configured to receive an subject to be scanned;
  - a subject positioner configured to place the subject to be scanned within the opening;
  - an (HF) electromagnetic energy projection source configured to project HF electromagnetic energy toward the subject to be scanned;
  - an HF electromagnetic energy detector array having a plurality of detector cells and configured to absorb HF electromagnetic energy passing through the subject to be scanned, wherein each detector cell includes:
    - an HF electromagnetic energy absorption component; and
    - a thermal sensing component;
  - a data acquisition system (DAS) connected to the detector array and configured to receive electrical signals from each thermal sensing component indicative of a change in temperature of a corresponding HF electromagnetic energy absorption component; and
  - an image reconstructor connected to the DAS and configured to reconstruct an image of the subject from the electrical signals received by the DAS.
8. The CT system of claim 7 incorporated into a medical diagnostic imaging device wherein the subject positioner includes a movable table and the subject to be scanned includes a medical patient.

9. The CT system of claim 7 incorporated into a non-invasive package/baggage inspection device wherein the subject positioner includes a conveyor apparatus and the subject to be scanned includes at least one of a package and a piece of baggage.

10. The CT system of claim 9 incorporated into at least one of a postal inspection security system and an airport security system.

11. The CT system of claim 7 wherein the HF electromagnetic energy absorption component includes material that undergoes a change in temperature in response to absorption of HF electromagnetic energy.

12. The CT system of claim 7 wherein the thermal sensing component includes one of a night vision IR thermal sensor and a room temperature microbolometer.

13. The CT system of claim 7 wherein the HF electromagnetic energy detector array includes one of a pixilated and a columnar orientation.

14. The CT system of claim 7 further comprising a collimator to reduce HF electromagnetic energy scatter from the subject to be scanned.

15. A detector array for a CT imaging system, the detector array comprising:

means for absorbing high frequency (HF) electromagnetic energy;

means for experiencing thermal differentials in response to absorbed HF electromagnetic energy;

means for detecting the thermal differentials; and

means for outputting a signal indicative of the HF electromagnetic energy absorbed based on the detected thermal differentials.

16. A CT detector array comprising:

a plurality of high frequency (HF) electromagnetic energy absorption cells comprised of a material configured to change in temperature in response to absorption of HF electromagnetic energy; and

a plurality of thermal sensing cells to sense changes in temperature of the plurality of HF electromagnetic energy absorption cells and output a signal indicative of the HF electromagnetic energy absorbed by the HF electromagnetic energy absorption component based on the change in temperature of the HF electromagnetic energy absorption cells.

17. The CT detector array of claim 16 wherein the plurality of HF electromagnetic energy absorption cells comprises at least one of tungsten, lead, and tantalum.

18. The CT detector array of claim 16 incorporated into a CT imaging system comprising:

a rotatable gantry having an opening therein and configured to receive an subject to be scanned;

a subject positioner configured to place the subject to be scanned within the opening;

a HF electromagnetic energy projection source configured to project HF electromagnetic energy toward the subject to be scanned;

a data acquisition system (DAS) configured to receive electrical signals from each thermal sensing cell; and

an image reconstructor connected to the DAS and configured to reconstruct an image of the subject from the electrical signals received by the DAS.

19. The CT detector array of claim 16 wherein each thermal sensing cell includes one of a night vision IR thermal sensor and a room temperature microbolometer.

\* \* \* \* \*